

## BANCO SEM COSTAS

### REFERÊNCIA

2074

### PESO

20 Kilos

### MATERIAL

Pinho Silvestre

### TRATAMENTO

Autoclave, tratamento castanho, classe de risco 4



### VISTA FRONTAL

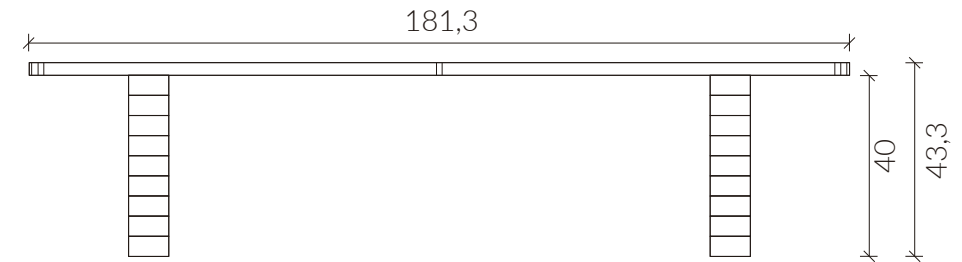

### VISTA SUPERIOR

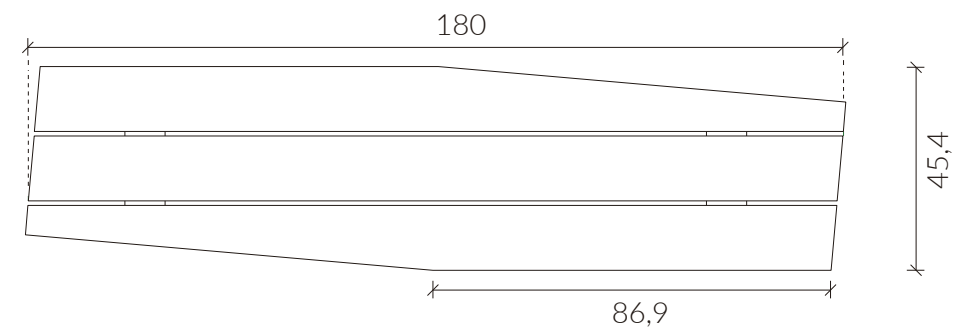

Unidade de medida: centímetros