

## PÉRGULA CARMO - TIPO A

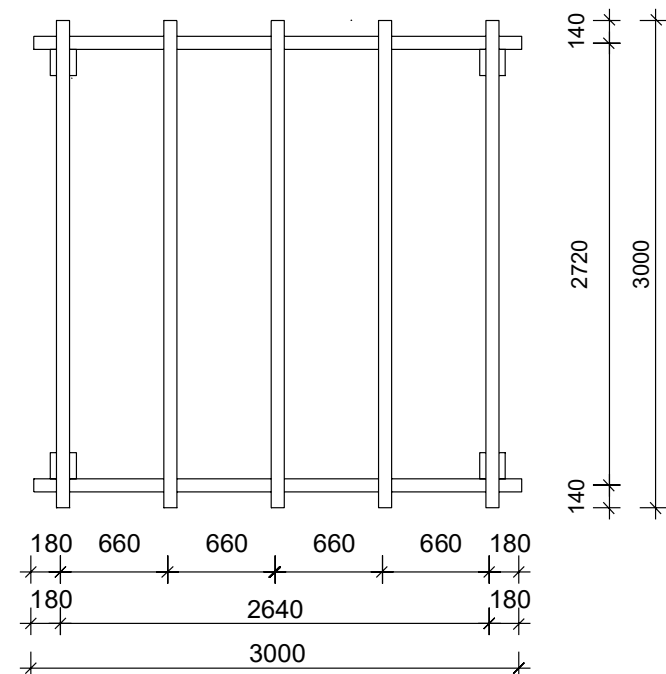

VISTA SUPERIOR



### COMPONENTES INCLUÍDOS

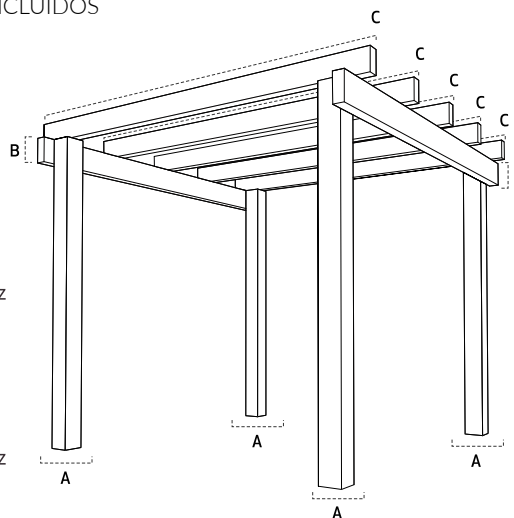
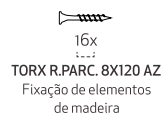
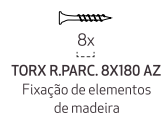
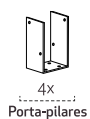
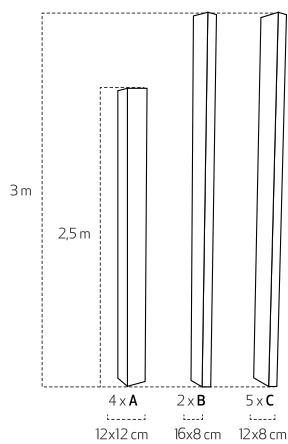

VISTA LATERAL

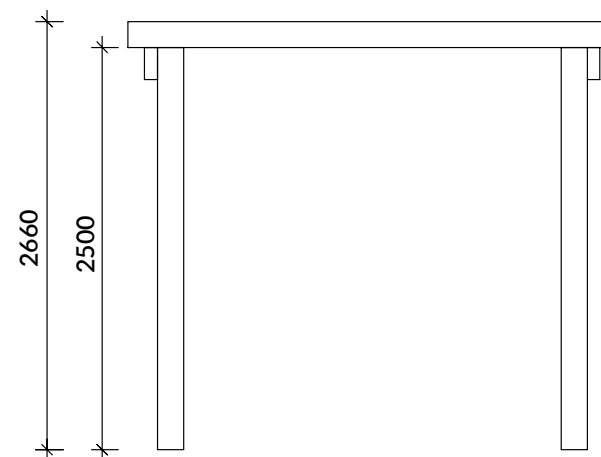

PESO - 350 Kilos

MONTAGEM - Necessita de montagem | Fornecimento em kit | Medidas da embalagem: 300x80x34 cm

Unidade de medida: milímetros

## PÉRGULA CARMO - TIPO B



### VISTA SUPERIOR

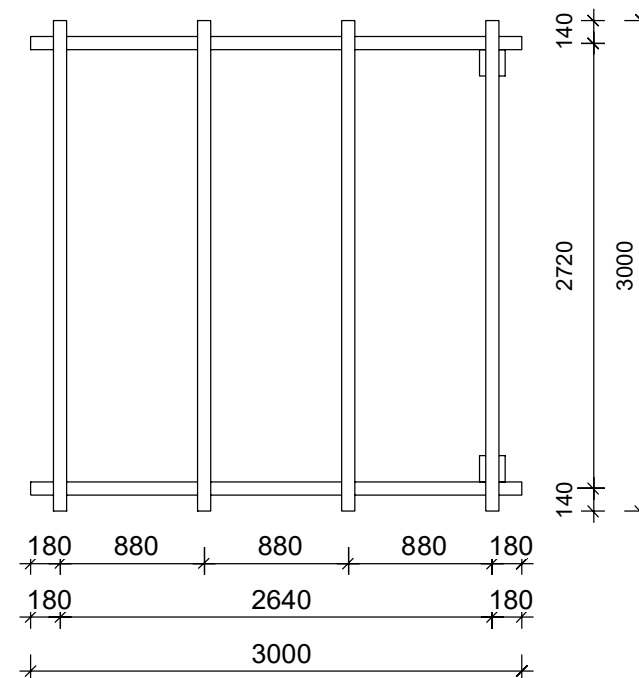

### COMPONENTES INCLUÍDOS

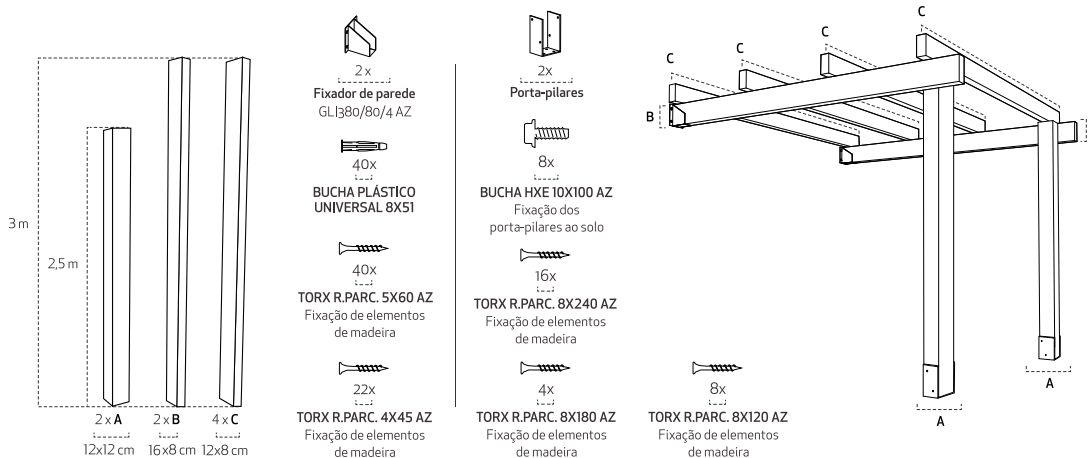

### VISTA LATERAL

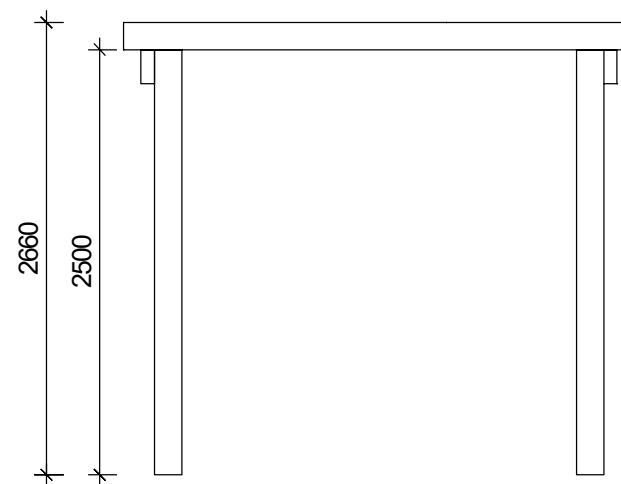

PESO - 250 Kilos

MONTAGEM - Necessita de montagem | Fornecimento em kit | Medidas da embalagem: 300x64x34 cm

Unidade de medida: milímetros

## PÉRGULA CARMO - TIPO C

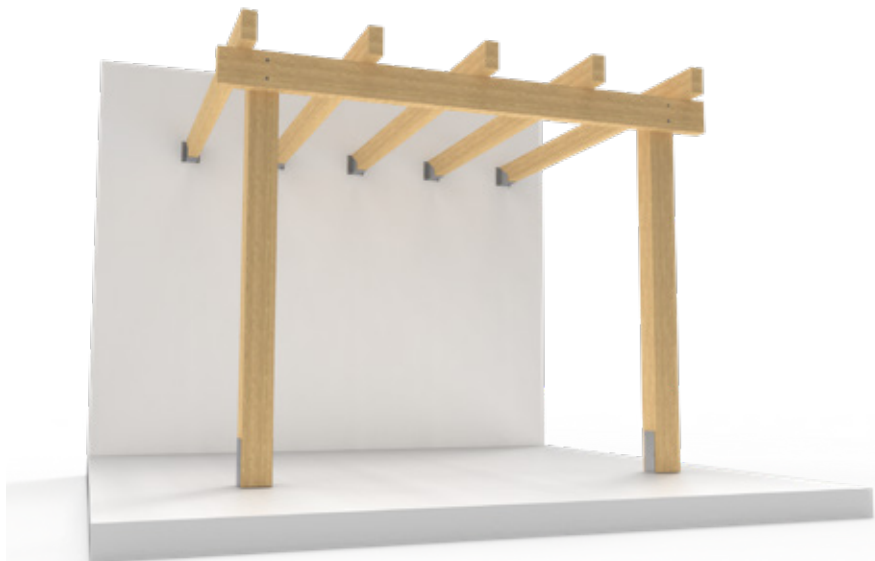

VISTA SUPERIOR

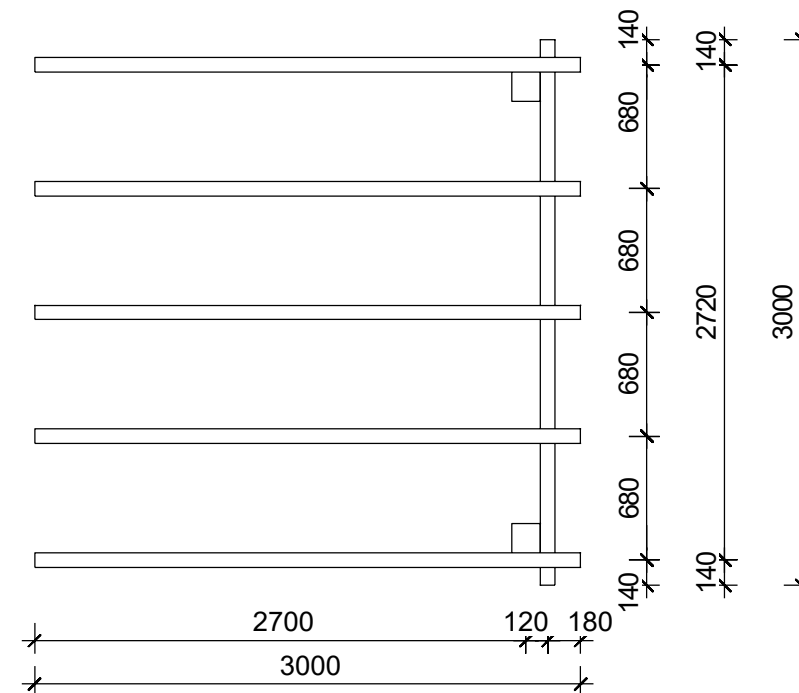

### COMPONENTES INCLuíDOS

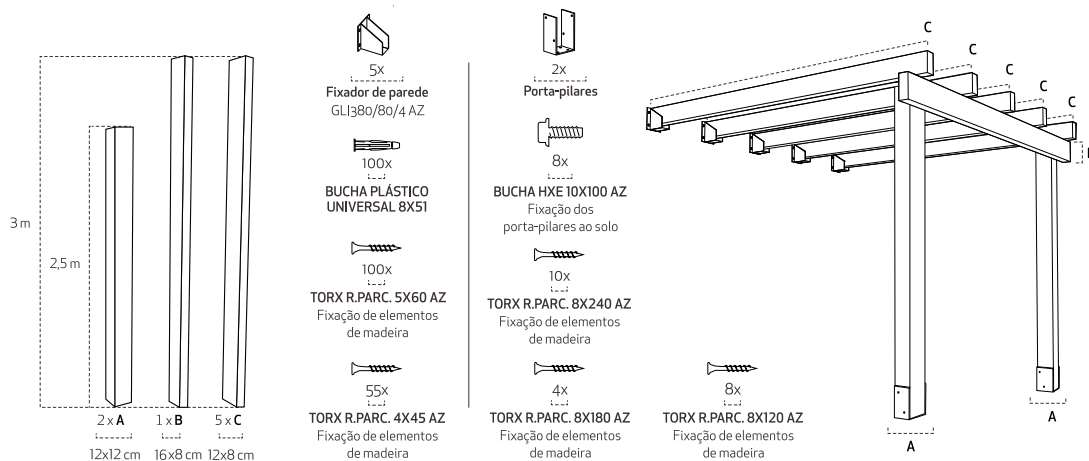

VISTA LATERAL

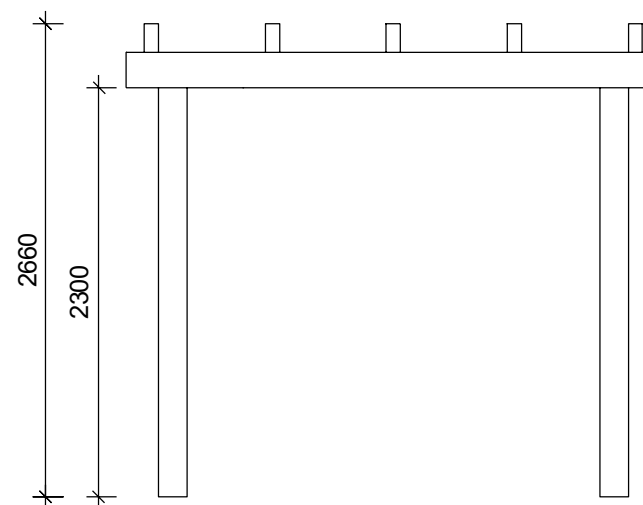

PESO - 240 Kilos

MONTAGEM - Necessita de montagem | Fornecimento em kit | Medidas da embalagem: 300x64x34 cm

Unidade de medida: milímetros

## PÉRGULA CARMO - TIPO D

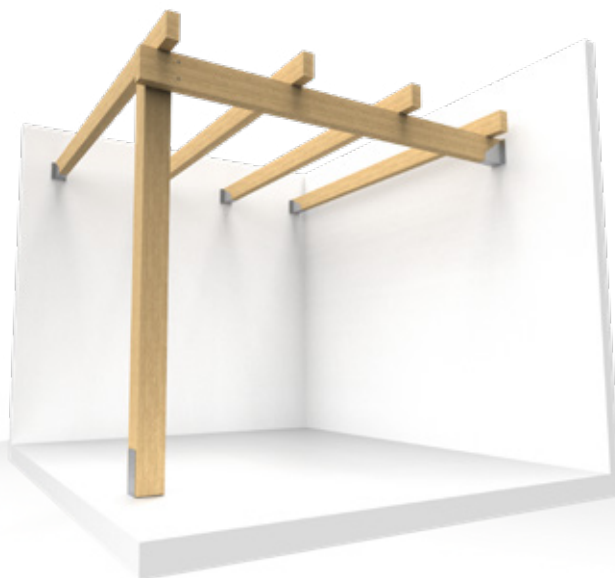

### COMPONENTES INCLUÍDOS

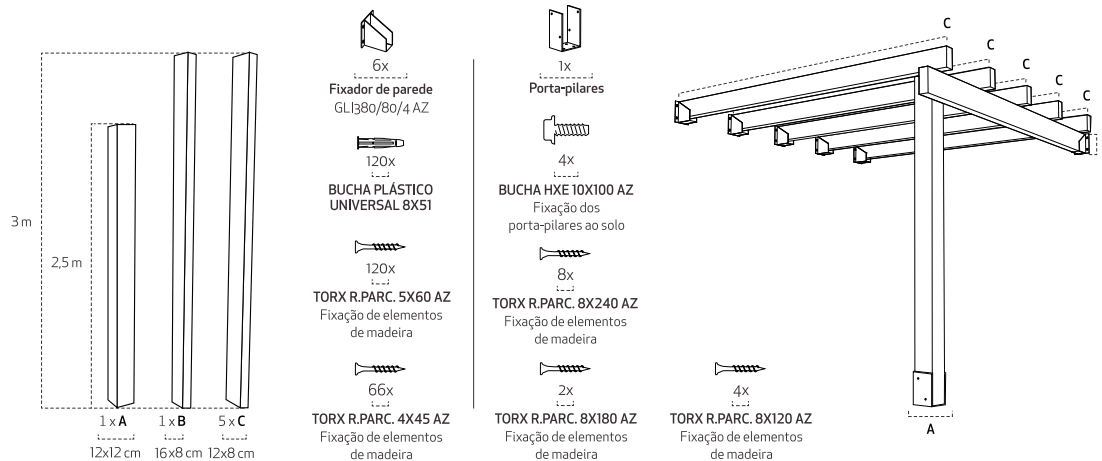

PESO - 180 Kilos

MONTAGEM - Necessita de montagem | Fornecimento em kit | Medidas da embalagem: 300x64x34 cm

### VISTA SUPERIOR

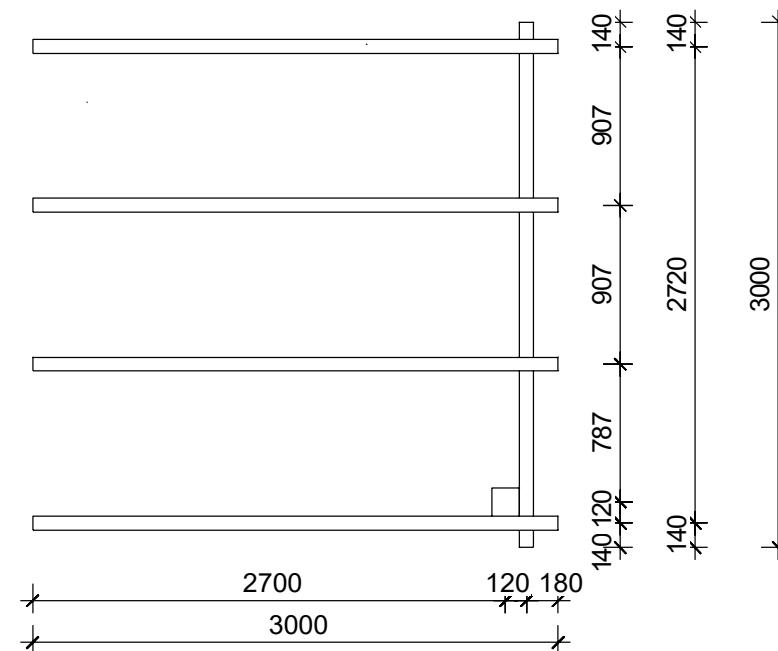

### VISTA LATERAL

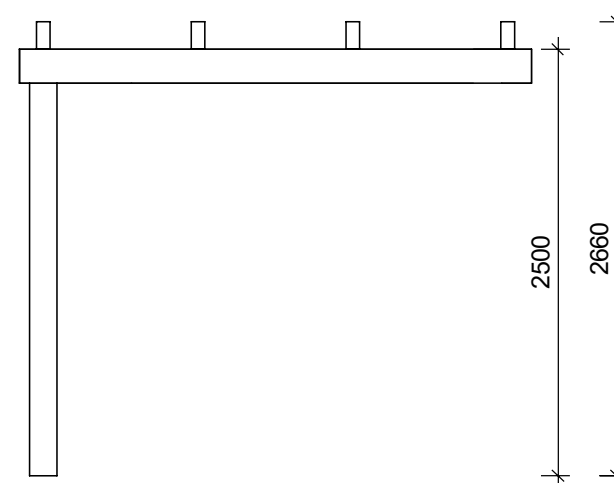

Unidade de medida: milímetros

## PÉRGULA CARMO - TIPO E



### COMPONENTES INCLUÍDOS

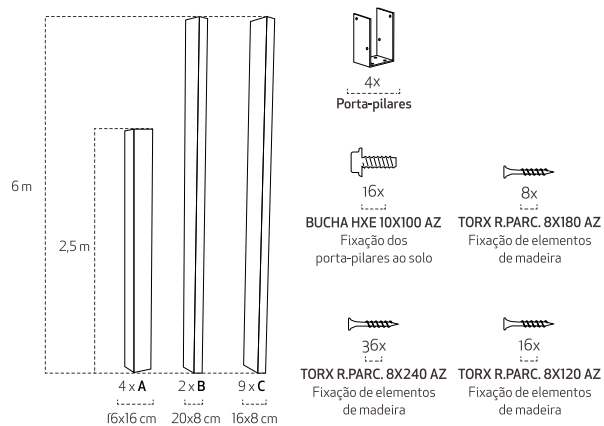

### VISTA SUPERIOR

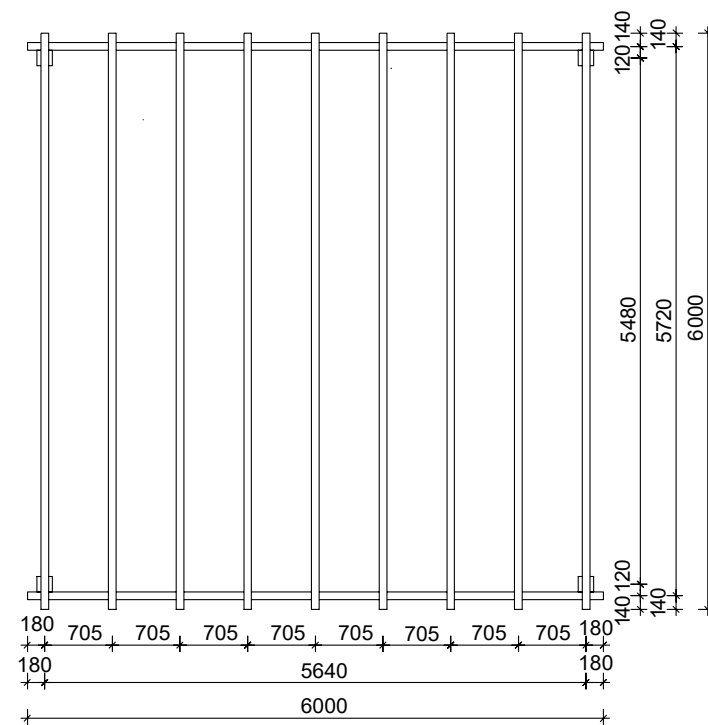

### VISTA LATERAL



PESO - 740 Kilos

MONTAGEM - Necessita de montagem | Fornecimento em kit | Medidas da embalagem: 600x100x42 cm

Unidade de medida: milímetros

## PÉRGULA CARMO - TIPO A+ B



### COMPONENTES INCLUÍDOS

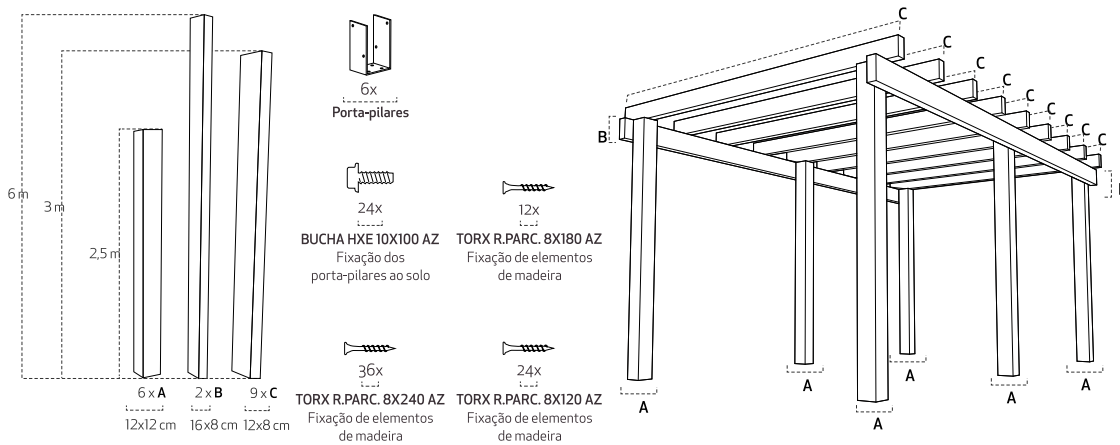

### VISTA SUPERIOR

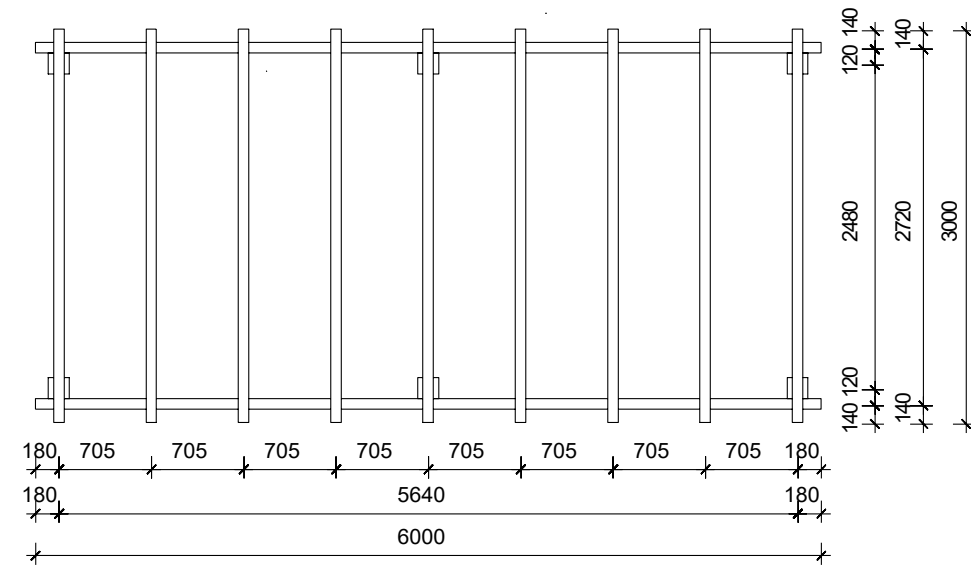

### VISTA LATERAL

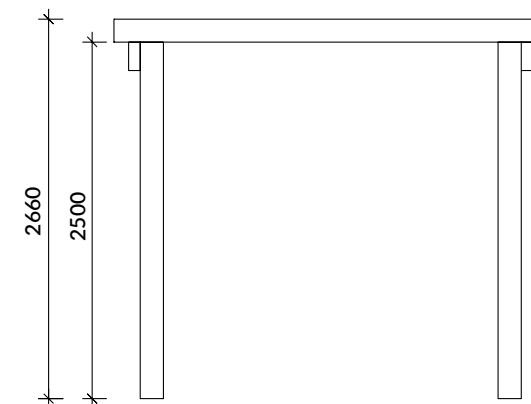

## PÉRGULA CARMO - TIPO A + C



VISTA SUPERIOR

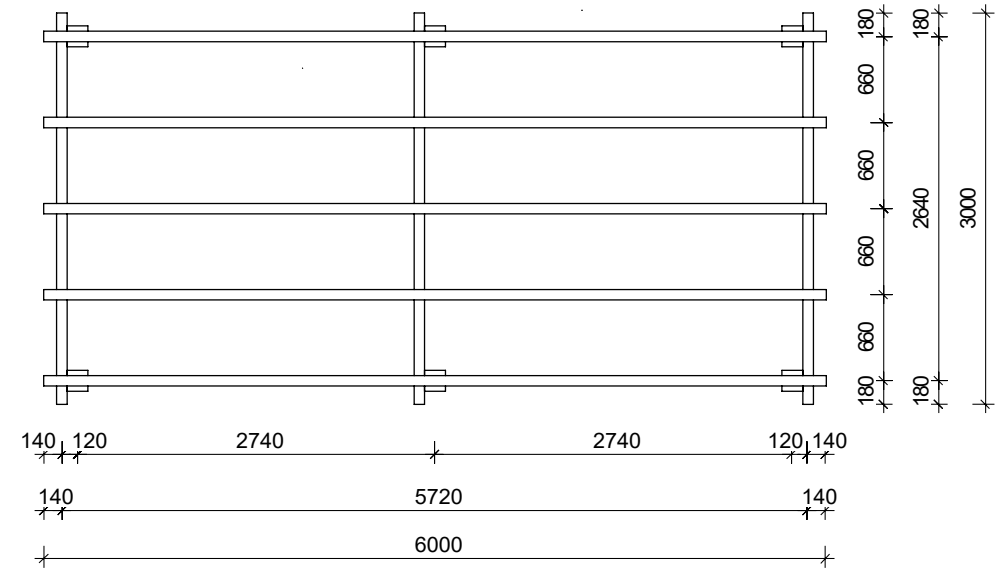

### COMPONENTES INCLUÍDOS

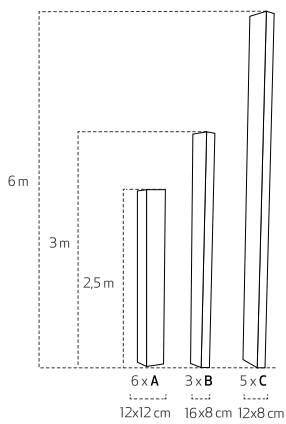

- 6x  
Porta-pilares
- 24x  
BUCHA HXE 10X100 AZ  
Fixação dos porta-pilares ao solo
- 12x  
TORX R.PARC. 8X180 AZ  
Fixação de elementos de madeira
- 30x  
TORX R.PARC. 8X240 AZ  
Fixação de elementos de madeira
- 24x  
TORX R.PARC. 8X120 AZ  
Fixação de elementos de madeira

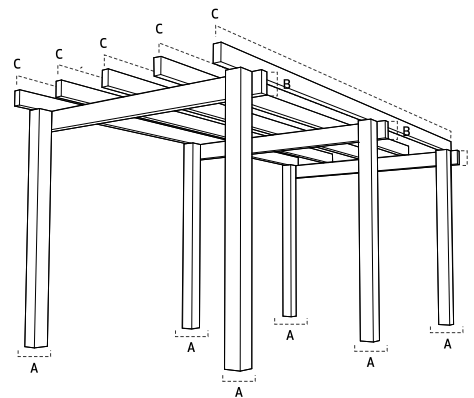

VISTA LATERAL

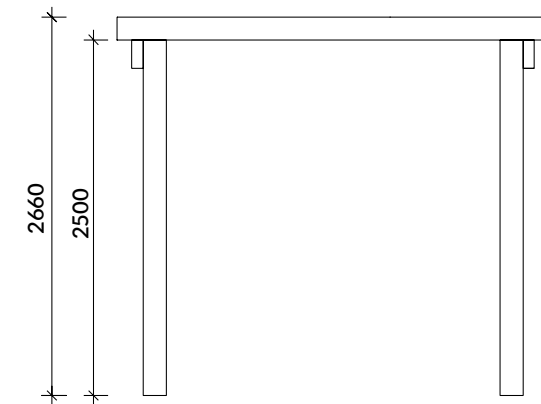

# PÉRGULA CARMO - TIPO A + B + C + D



## COMPONENTES INCLUÍDOS

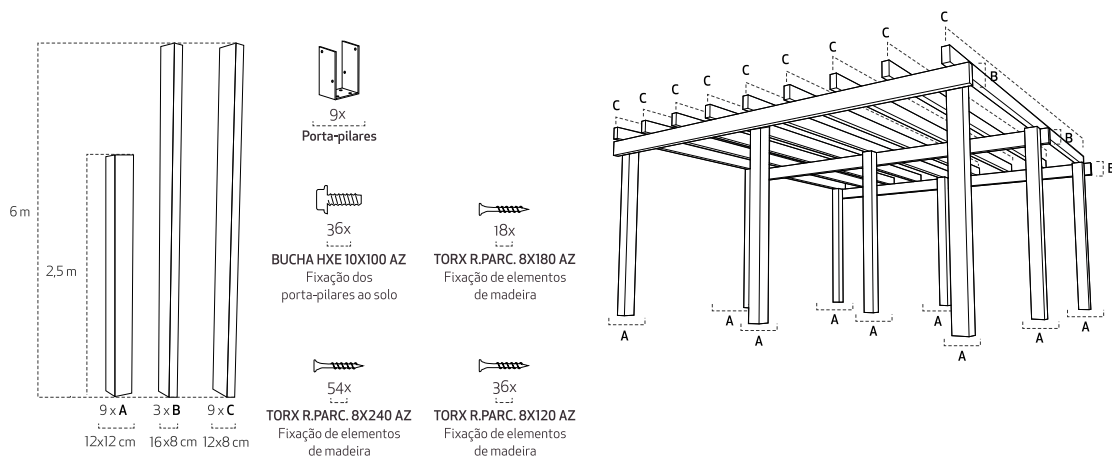

## VISTA SUPERIOR

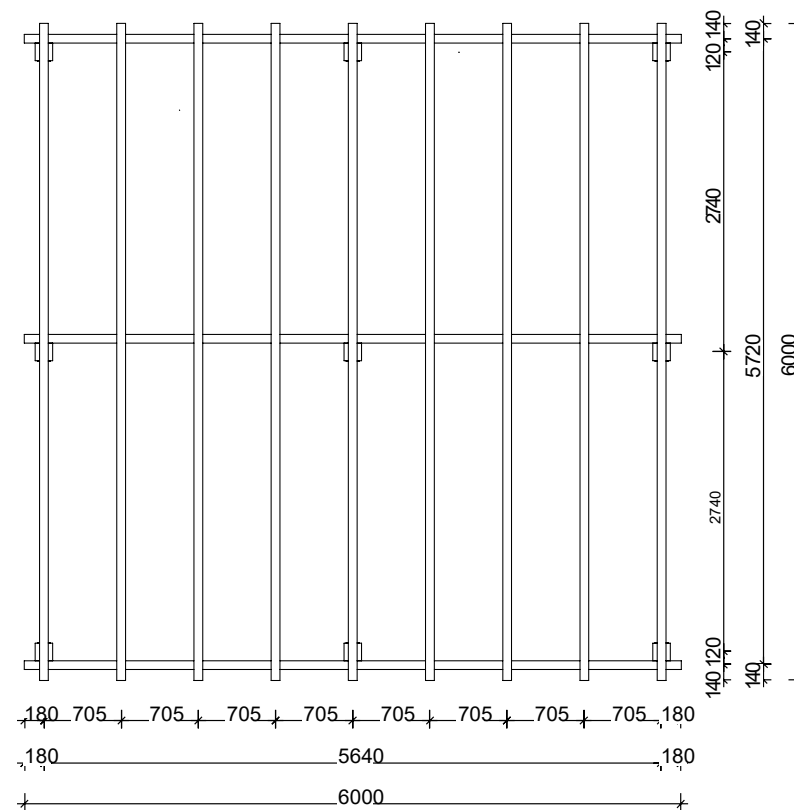

## VISTA LATERAL

